

Dimensions (Unit: mm)

L type

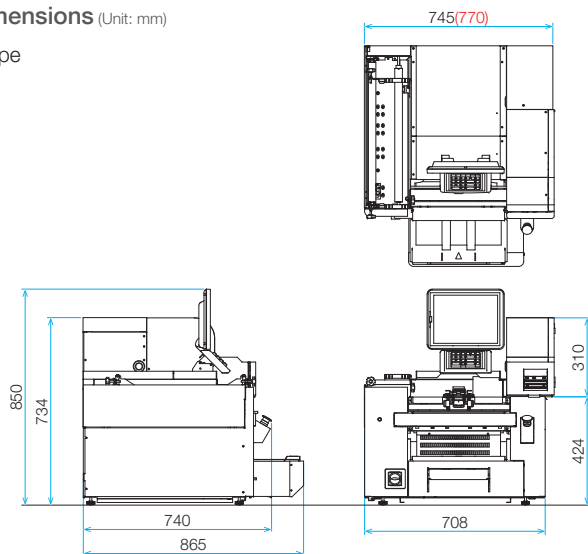

LL type

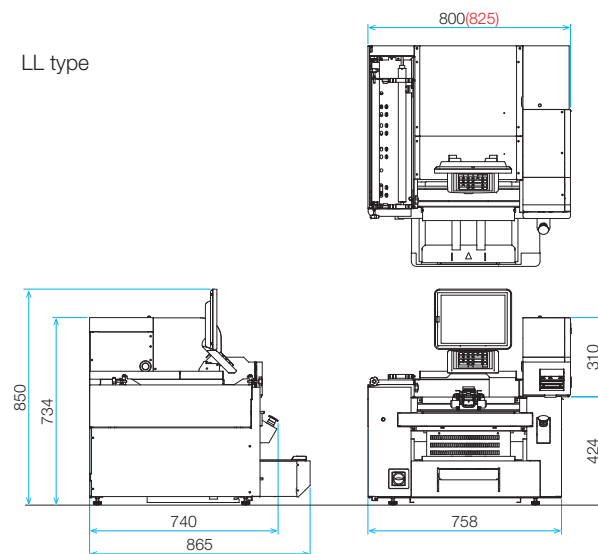

*Dimensions in red are for Linerless model.

Specifications

Model		WM-MICRO	
		L type(With liner / Linerless)	LL type(With liner / Linerless)
Scale unit	Weighing capacity	Multi-interval: 0-6 kg × 0.002 kg / 6-15 kg × 0.005 kg	
	Weighing accuracy	1/3000	
	Minimum wrapping weight	0.04 kg (0.1 lb)	
	Wrapping capacity	0.04-3.5 kg (0.1-7.72 lb)	
Wrapping unit	Packs per minute (MAX)	15 packs/min	
	Wrapping size*1	Width: 150-350 mm Depth: 127-230 mm Height: 10-130 mm	Width: 150-380 mm (5.91-14.96 inch)*2 Depth: 127-230 mm (5.00-9.05 inch) Height: 10-130 mm (0.40-5.11 inch)
	Tray type	PSP, PP, PET, Paper*3	
	Film type	Polyolefin / PVC (film type suitable for automatic wrapping)	
Printer unit	Film size	400, 450, 500 mm	
	Film outside diameter	ø200 mm or less	
	Print head	3 inch direct thermal (960 dots), 12 dots/mm	
	Printing speed	120 mm/sec	
	Print area	With liner Width: Up to 76 mm (2.99 inch)	Linerless Width: Up to 77 mm (3.03 inch)
	Label size	With liner Width: 33-80 mm (1.30-3.14 inch)	Length: 23-105 mm (0.91-4.13 inch)
	Label roll size	ø125 mm (4.92 inch)	
	Inner core diameter	ø40 ±1.0 mm (1.57 ±0.03 inch)	
	Label storage capacity	With liner 1820 labels/roll*4	Linerless 2700 labels/roll*4
	Controller unit	Display	Backlit 12.1-inch color LCD touch-panel (SVGA : 800 × 600 dots)
Tactile keys		19 keys	
Interface		USB: 4ch 10/100base-TX: 1ch	
Memory capacity		1GB	
Power supply		Single phase, 200-240V, 50/60Hz	
Power consumption (MAX)*5		Operation: 1300W or less Standby: 1100W or less Sleep mode: 200W or less	
Operational environment*6	Temperature	5-35°C	
	Humidity	20-85%RH (without condensation)	
Machine weight		Approx. 130 kg (280 lb)	
Noise level		73 dB or less	
Option		Tenkey cover, Anti-static wire, Wireless LAN unit, Film roll protection cover unit, -10 mm infeed pusher	

*Inch values are those in millimeters (mm) rounded down to the third decimal place.

*1) Depends on the conditions. *2) For the LL type, the 25SH - 380 × 210 × 30mm (14.96 × 8.26 × 1.18 inch) can be packaged. However, there are certain conditions that need to meet.

*3) Depends on product and tray size requirements. *4) With liner: at 37 mm (1.45 inch) height and 2.5 mm (0.09 inch gap). Linerless: 37 mm (1.45 inch) height.

*5) Power consumption varies depending on site conditions and machine setup.

*6) Printable environment depends on label's specifications. Operation environment for dedicated labels (for linerless label only): Temperature: 5-30°C, Humidity: 30-75%RH (without condensation)

The information in this catalog is current as of July 12, 2024.

The company name and product name described in this catalog are registered trademarks.

The machine color in this catalog might be different from the real machine.

The described machine appearance and specifications in this catalog are subject to change without any notification.



ISHIDA CO., LTD. www.ishida.com

44 Shogoin Sannocho, Sakyo-ku,
Kyoto, 606-8392, Japan
Tel: +81 (0)75 771 4141



Table-top Wrapper

WM-MICRO



Weighing

Packing

Inspection

Display

Sell

Minimize Space, Maximize Efficiency

An all-in-one solution for efficient weighing, wrapping and labeling.

WM-MICRO



Compact

The WM-MICRO is a fully automatic wrapping machine with an integrated scale and printer. By leveraging wrapping technology cultivated over the years, this wrapper is compact enough to be installed in a backroom area with limited space.

Capable

The WM-MICRO offers a high-performance printer with a 3-inch print head and 12 dots/mm resolution. It is designed for wrapping various types of trays, such as large and tall trays to support a wide variety of products. An eco-friendly linerless label model is also available.

Comfortable

Its 12.1-inch panel is easy for operators to read and use. The WM-MICRO delivers high-quality automatic wrapping while reducing repetitive work for the operator.

Compact

Space Saving

The WM-MICRO is compact enough to be installed on a work table and is smaller than a hand wrapper. Replacing an existing hand wrapper with the WM-MICRO is simple and easy.

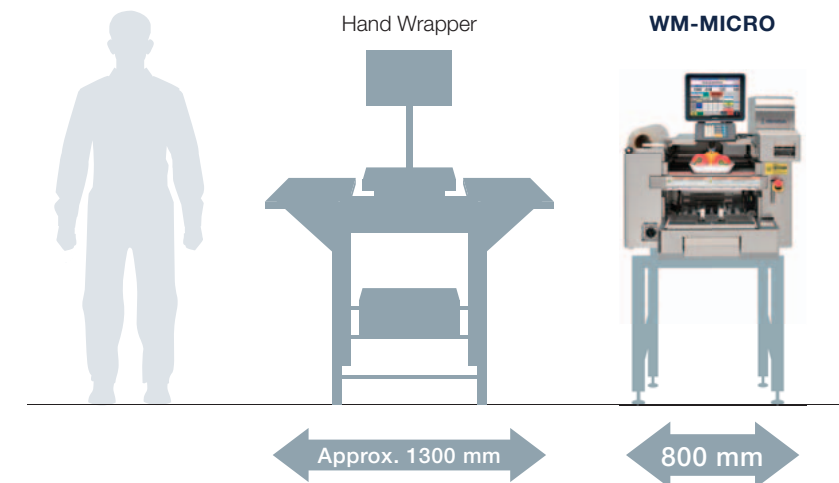

Capable

Wrapping Capabilities for Various Tray Sizes

The WM-MICRO is capable of wrapping various types of trays using its unique wrapping technology. It uses high-quality and stable wrapping to minimize the number of wrapping defects and reduce waste.

Size

- Small trays
- 25SH large trays*1
- Tall trays

Materials

- Eco-friendly PET
- Paper trays*2

Shape

- Rectangle
- Square

*1) Only for LL type *2) Depending on product and tray size and labeling requirements.



This automatic wrapper is capable of feeding a tall and unbalanced tray without damage and also wraps 25SH trays*1 for North American markets.



3-inch Print Head and 12 dots/mm

Its PC-based system enables the printing of True-Type fonts. This allows for attractive, clear and easy-to-read text in a flexible label format.



Price label



Supports various fonts

Price and nutritional information label



Ingredients and meat traceability information label

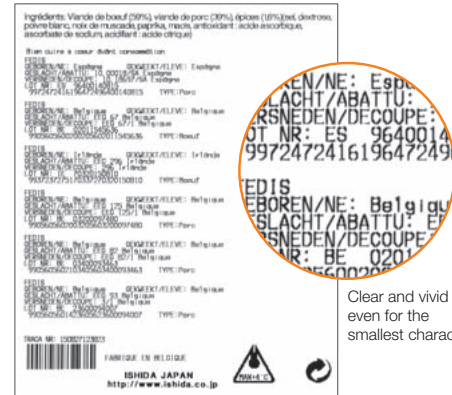

Clear and vivid even for the smallest character

More Labels Per Roll

The WM-MICRO supports a label roll diameter of 125 mm to reduce label roll replacements and workload.

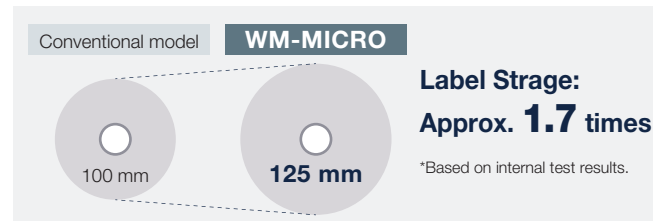

Eco-friendly Linerless Model Available

The linerless label model automatically cuts labels into an appropriate size.

Flexible Label Designs:

The label length can be changed to support printing with flexible designs. It can reduce the vacant space or expand the label length to have additional information, such as food safety information and promotional images.



	With liner label		Linerless label	
Backing Paper Waste	233 g	251 g	0 g	18 g
Label Core Waste	18 g		18 g	
Annual Waste	79.8 kg		3.7 kg	

Label size: 60 x 60 mm, Annual production in 1000 packs / day, 350 days

Achieve a waste reduction of 76.1 kg with annual production of 1000 packs.

Increased 1.5 times as much in the number of labels.



1100 labels

1666 labels

Minimum Downtime and Operation Cost

*Based on an in-house survey in June 2024.

Waste Reduction:

Linerless labels offer both environmental benefits and economic advantages. No backing paper achieves reduction in waste and disposal costs, while also contributing to the reduction of CO₂ emissions. Additionally, it enables lower transportation costs and energy savings.

Minimum Downtime and Running Costs:

Linerless labels feature more labels per roll and more usage per roll than With liner labels. They reduce roll replacements, order frequency and shipping costs. It also allows the efficient use of storage space, achieving both environmental contribution and cost reduction.

*For any inquiries about the linerless label model, contact your local Ishida distributor.

Comfortable

User-friendly operation

The WM-MICRO's large 12.1-inch display is easy-to-read and has a responsive interface powered by LINUX OS to support intuitive operation.

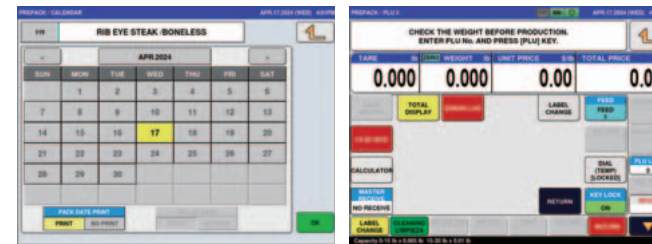

Pack/Sell by dates can be selected even in a calendar format.

Easy registration of frequently used preset keys.



Easy Operation Reduces Downtime

The WM-MICRO's design is user-friendly to maximize operational efficiency. Without any difficult steps, film and label roll replacements are easy, even for beginners. Machine cleaning and error handling can also be conducted with minimum downtime.



Save Time with Faster Operation

Wrapping Capabilities

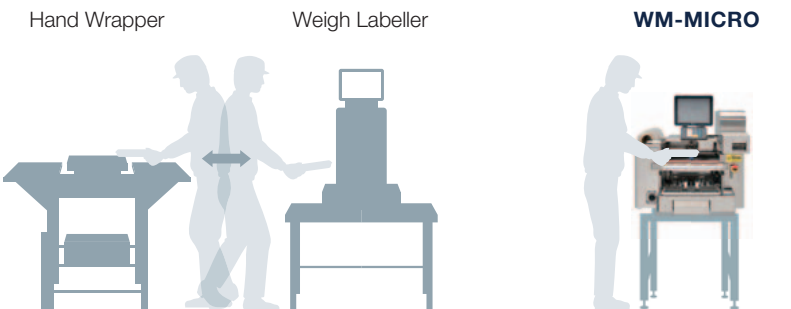

	Hand Wrapper	Weigh Labeller	WM-MICRO
Wrapping			
Labelling		Approx. 6 packs/min* + MOVE	MAX 15 packs/min
When wrapping 500 packs		1 hour 23 minutes 20 seconds* + MOVE	33 minutes 20 seconds

Additional Benefit

Labor-saving	Beautiful wrapping	Fast stocking	Almost no physical load
--------------	--------------------	---------------	-------------------------

*Based on an in-house survey.