



Virtual  
Measurements  
& Control

If you can conceive it, we can measure and control it  
Virtual Measurements & Control (Asia) Pte Ltd



# VMC CHECKWEIGHER VAC-SW SERIES

## FEATURES:

### HMI Display

7" color Touch Screen Interactive Menu & Set up  
Digital Speed Control on TFT panel

### High Performance

Digital Filter DSP  
(Digital Signal Processing)  
16 Bit AD conversion

### Data Communication

Data download by Excel format via USB drive (Standard)  
Data opening at Excel program in computer.  
RS422 /RS-232C Communication option

### Easy to maintenance

Stainless Steel finishing (Polished)  
IP54 Splash Proof & dust protection  
(IP67 Option)  
Clip-on conveyor for easy cleaning

### Interlock with other machine (Option)

Random weight checking system interlocked with bar code  
Packaging machines Interfacing program to control filling weight



OPERATION DISPLAY



MENU DISPLAY



X-BAR SCREEN DISPLAY



PRODUCT JUDGMENT MENU DISPLAY



STATS DISPLAY

VMC Checkweigher is easily configure and integrated into various applications including food processing, consumer packaged goods, material handling, logistics and distribution, pharmaceutical production and many other applications.

VMC checkweigher can be use as a stand alone machine, at the same time can be integrated with metal detector, Horizontal Flow Wrapping Machine, X-Ray system and Rejector.

# VAC-SW SERIES

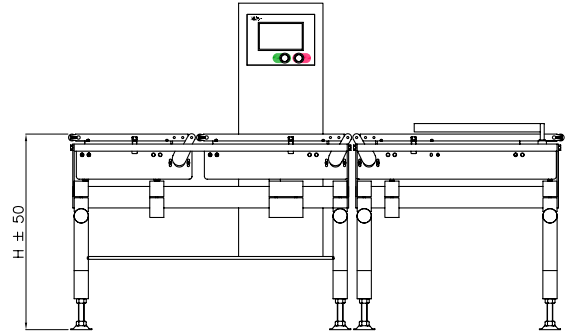
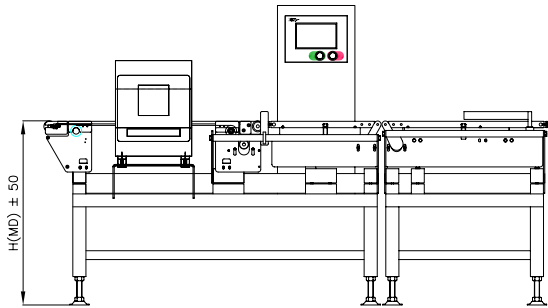
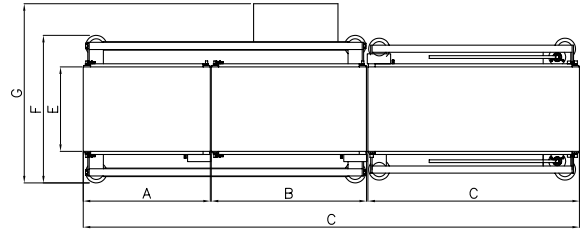
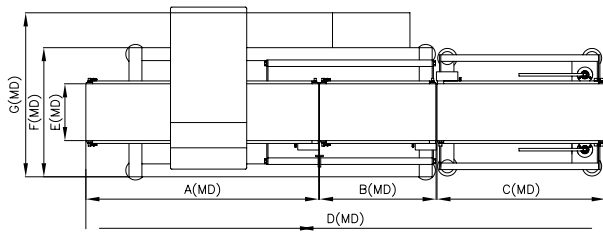

\*Applicable with Metal Detector (Combi unit)

Model	A	B	C	D	E	F	G	H
VAC-SWL210-I	350	250	450	1070	100	550	610	Standard Conveyor Height 750mm (+/-50)
VAC-SWL615-I	450	350	550	1370	150	550	610	
VAC-SWL1222-I	350	450	650	1470	220	550	610	
VAC-SWM330-I	450	550	750	1770	300	550	650	
VAC-SWM636-I	550	650	850	2070	360	550	680	

## SPECIFICATIONS – VAC-SWL & VAC-SWM Series Checkweigher

Model VAC-SW	VAC-SWL210-I		VAC-SWL615-I		VAC-SWL1222-I		VAC-SWM330-I		VAC-SWM636-I		
	VAC-SWL210-M		VAC-SWL615-M		VAC-SWL1222-M		VAC-SWM330-M		VAC-SWM636-M		
<b>Maximum Capacity</b>	200g		600g		1,200g		3,000g		6,000g		
<b>Weighing Range</b>	1g ~ 200g		1g ~ 600g		1g ~ 1,200g		3g ~ 3,000g		3g ~ 6,000g		
<b>Scale Interval</b>	0.05g		0.1g		0.1g		0.5g		1.0g		
<b>Maximum Accuracy*</b>	+/- 0.1g		+/- 0.2g		+/- 0.2g		+/- 1.0g		+/- 2.0g		
<b>Maximum Weighing Speed**</b>	250ea/min		220ea/min		220ea/min		150ea/min		100ea/min		
<b>Conveyor Speed</b>	10 ~ 70 m/min		10 ~ 80 m/min		10 ~ 100 m/min		10 ~ 85 m/min		10 ~ 70 m/min		
<b>Product Max. (mm)</b>	Width	10 ~ 100 mm		10 ~ 150 mm		10 ~ 220 mm		10 ~ 300 mm		10 ~ 360mm	
	Length	30 ~ 200 mm		50 ~ 250 mm		50 ~ 350 mm		70 ~ 350 mm		70 ~ 450 mm	
	Height	5 ~ 100 mm		5 ~ 150 mm		5 ~ 220 mm		5 ~ 300 mm		5 ~ 360 mm	
<b>Applicable Rejectors</b>	Flip Bar	FB3 - 1045		FB3 - 1555		FB3 - 2265		FB3 - 3075		FB3 - 3085	
	Pusher Bar	PB2 - 1035		PB2 - 1545		PB2 - 2245		PB2 - 3055		PB2 - 3665	
	Air Jet	AJ3 - 1035		AJ3 - 1555							
	Belt Drop	DB2 - 1035		DB2 - 1545		DB2 - 2245		DB2 - 3055		DB2 - 3665	
<b>Metal Detector (System Square)</b>	SDII30XX		SDII30XX		SDII30XX		SDII45XX		SDII45XX		
<b>Power Requirements</b>	220VAC+/-10%, single Phase, 50/60Hz										
<b>Environmental Conditions</b>	5°C ~ 35°C (41°F ~ 95°F), Variation not to exceed +/-2°C (4°F)/hr, Relative Humidity: 35% ~ 85%										
* Maximum Accuracy may change depending on the product conditions.											
** Maximum Weighing Speed may change depending on the product dimension and conveyor speed.											



Virtual Measurements & Control

If you can conceive it, we can measure and control it

Virtual Measurements & Control (Asia) Pte Ltd

Virtual Measurements & Control (Asia) Pte Ltd

5 Tanjong Penjuru Crescent Singapore 608970

Tel: (65) 6361 0610 | Fax: (65) 6763 6656

Email: sales@virtualmc.com

www.virtualmc.com

Distributed by: